

GRAIN

CN operates a wide range of covered hoppers to meet the needs of the industry. These cars combine ease of loading and unloading with maximum protection from the elements

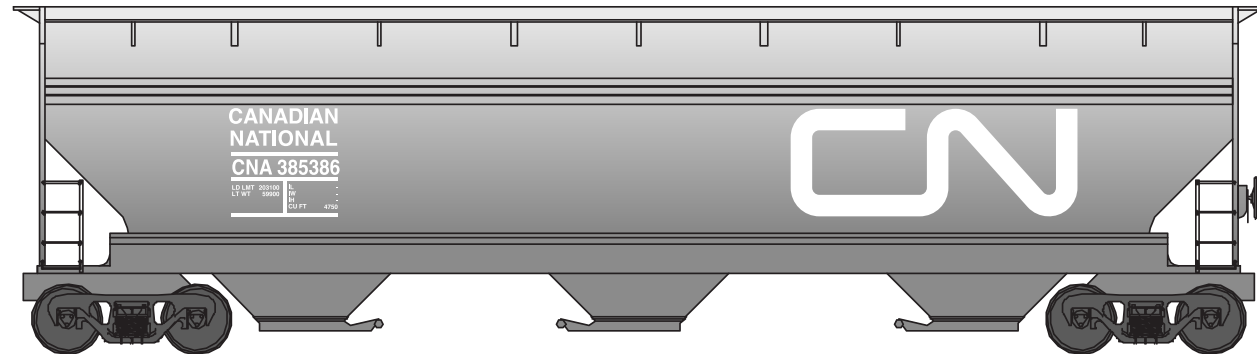

46' 0" TRUCK CENTERS
 55' 0" END SILLS
 56' 4-1/2" STRIKERS
 59' 0" COUPLERS

HIGH-CUBE AND JUMBO COVERED HOPPER (US)

Car Description	Car Series	Load		Capacity		Outside Dimensions	
		Tons	Tonnes	Cu. ft.	m ³	Length	Width
High-Cube Hopper CN's high-cube hopper fleet offers customers carrying capacities ranging from 99-102 tons.	GTW 138200-138449	101-102	92-93	4,750	135	60' 0"	10' 8"
	CN 382001-382699	99-101	90-92	4,550	129	59' 0"	10' 8"
	CN/CNA 383000-385999	99-102	90-93	4,650-4,750	132-135	60' 0"	10' 6" - 10' 8"
	CC 475036-488706	100-102	91-93	4,750	135	60' 0"	10' 8"
	IC 755000-755499	99-100	90-91	4,700	133	54' 11"	10' 8"
	CC/IC/ICG 764305-769736	98-102	89-93	4,650-4,750	132-135	59' 0" - 60' 0"	10' 7" - 10' 8"
	CC 800016-800880	101-102	92-93	4,750	135	60' 0"	10' 6" - 10' 8"
Jumbo Hopper	CN 388000-389299	112-113	102-103	5,250	149	58' 0"	10' 8"
	IC 798000-799949	111-112	101-102	5,150-5,200	146-147	57' 0" - 60' 0"	10' 7" - 10' 8"